

PART NUMBER

SSF-403-54



SCAN HERE: To watch a video of this installation



BEFORE YOU BEGIN

PRIMARY APPLICATIONS

- > Jeep Wrangler 4 X 4
(2007 - present)
- > Jeep Gladiator 4 X 4
(2020 - present)

PARTS LIST

Item	Part #	Description	QTY
A	511450	SumoSprings Yellow -54	2
B	512109	1" Spacer	2
C	512227	3/8 Flat Washer	2
D	512306	7/16-14 x 3 1/4" Hex Bolt	2

TOOLS REQUIRED

- > Floor Jack
- > Jack Stands
- > Wheel Chocks
- > Sockets and Wrench

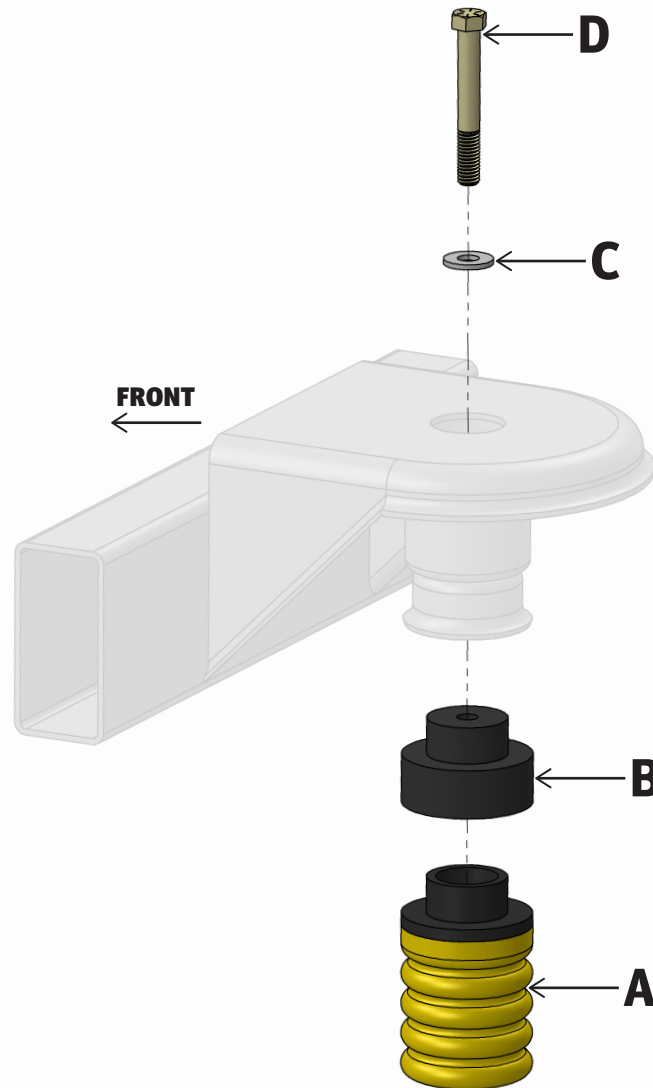

DRIVER SIDE (PASSENGER SIDE SIMILAR)

Part Number: SSF-403-54

Product Line: SUMOSPRINGS FRONT

Page 1

Questions or Concerns?

Scan here:



or visit:
superspringsinternational.com

SAFETY NOTICE: We recommend installation be done by a professional or persons with sound mechanical knowledge.

WARNING: These instructions are a general guide for installation. SuperSprings International (SSI) assumes no liability for the actual installation process. Consumers and installers should apply common automotive safety practices when raising and working on any vehicle. **Do not put yourself in a position where, if the vehicle were to move unexpectedly, you may be injured.** SSI's products are designed to improve vehicle ride quality. Do not load any vehicle beyond the manufacturer's specifications.

Never exceed the manufacturer's Gross Vehicle Rating (GVWR) located on your vehicles identification tag.

BEFORE INSTALLATION: Ensure the vehicle is on a hard level surface, the parking brake is ON, with the ignition OFF, and place chocks in front of and behind the tires to prevent the vehicle from moving.

DURING AND/OR AFTER INSTALLATION: Ensure emergency brake cables are not touching the SSI products. Secure any cables out of the way with zip ties or by re-routing. Ensure all A/C lines, brake cables, and frame are clear of contact or interference.

REV. 2.01 | JUN 2023

PART NUMBER

SSF-403-54



INSTALLATION

1. Park the vehicle on a hard, level surface and engage the emergency brake. Place chocks in front and behind wheels to prevent rolling. Observe all safety precautions and wear safety glasses.
2. Raise the front of the Jeep, allowing the axle to hang freely. Support the frame using safety jack stands and remove the front wheels.
3. Disconnect the sway bar and shocks from the axle, then disconnect the draglink from the pitman arm.
4. Lower the axle far enough to remove the front coil so that you can remove the existing factory bump stop from the frame.
5. Place the 1" Spacer [ITEM B] on the top of the SumoSprings [ITEM A].
6. Insert the top of the Spacer/SumoSpring assembly into the bump stop mounting cup on frame and attach it with the 3/8 Flat Washer [ITEM C] and 7/16-14 x 3 1/4" Hex Bolt [ITEM D].
7. Reinstall the coil and reattach the draglink, shocks, and sway bar.
8. Raise the vehicle to allow room to remove the safety jack stands. If front wheels were removed you can now reinstall the front wheels and torque wheel nuts to manufacturers specifications.
9. Carefully lower vehicle to the hard surface and remove the chocks from the wheels.
10. Register the warranty for your SuperSprings International part. A warranty card can be found in the box your part came in.

Part Number: SSF-403-54

Product Line: SUMOSPRINGS FRONT

Page 2

Questions or Concerns?

Scan here:



or visit:
superspringsinternational.com

SAFETY NOTICE: We recommend installation be done by a professional or persons with sound mechanical knowledge.

WARNING: These instructions are a general guide for installation. SuperSprings International (SSI) assumes no liability for the actual installation process. Consumers and installers should apply common automotive safety practices when raising and working on any vehicle. **Do not put yourself in a position where, if the vehicle were to move unexpectedly, you may be injured.** SSI's products are designed to improve vehicle ride quality. Do not load any vehicle beyond the manufacturer's specifications.

Never exceed the manufacturer's Gross Vehicle Rating (GVWR) located on your vehicles identification tag.

BEFORE INSTALLATION: Ensure the vehicle is on a hard level surface, the parking brake is ON, with the ignition OFF, and place chocks in front of and behind the tires to prevent the vehicle from moving.

DURING AND/OR AFTER INSTALLATION: Ensure emergency brake cables are not touching the SSI products. Secure any cables out of the way with zip ties or by re-routing. Ensure all A/C lines, brake cables, and frame are clear of contact or interference.

REV. 2.01 | JUN 2023