

PART NUMBER
SSA19



BEFORE YOU BEGIN

TOOLS REQUIRED

- › Floor Jack
- › Safety Jack Stands
- › Wheel Chocks
- › ¾" Wrench/Socket
- › ½" Wrench/Socket
- › Heavy Duty Clamps or SuperSprings Installation Tool

PRIMARY APPLICATIONS

- › Toyota Tacoma 4 X 2 (2005 - 2013)
- › Toyota Tacoma 4 X 4 (2005 - 2013)

PARTS LIST

Item	Part #	Discription	QTY
A	102003	SSA19 SuperSpring	2
B	112140	Polyurethane Bushing	8
C	112213	Polyurethane Bump Stop	2
D	112221	Clamp Plate	2
E	111023	Mounting Block	2
F	112205	5/16-18 x 1 ½" Hex Bolt	4
G	112209	5/16 Flat Washer	8
H	112208	5/16-18 Nylock Nut	4
I	122402	Square Shackle	4
J	122400	Angled Shackle	4
K	112124	½-13 x 2 ¾" Hex Bolt	4
L	112125	½-13 x 4 ½" Hex Bolt	4
M	112126	½-13 Nylock Nut	8
N	112127	½" Nylon Flat Washer	16
O	112129	Steel Sleeve	4
P	112189	HDPE Roller	4

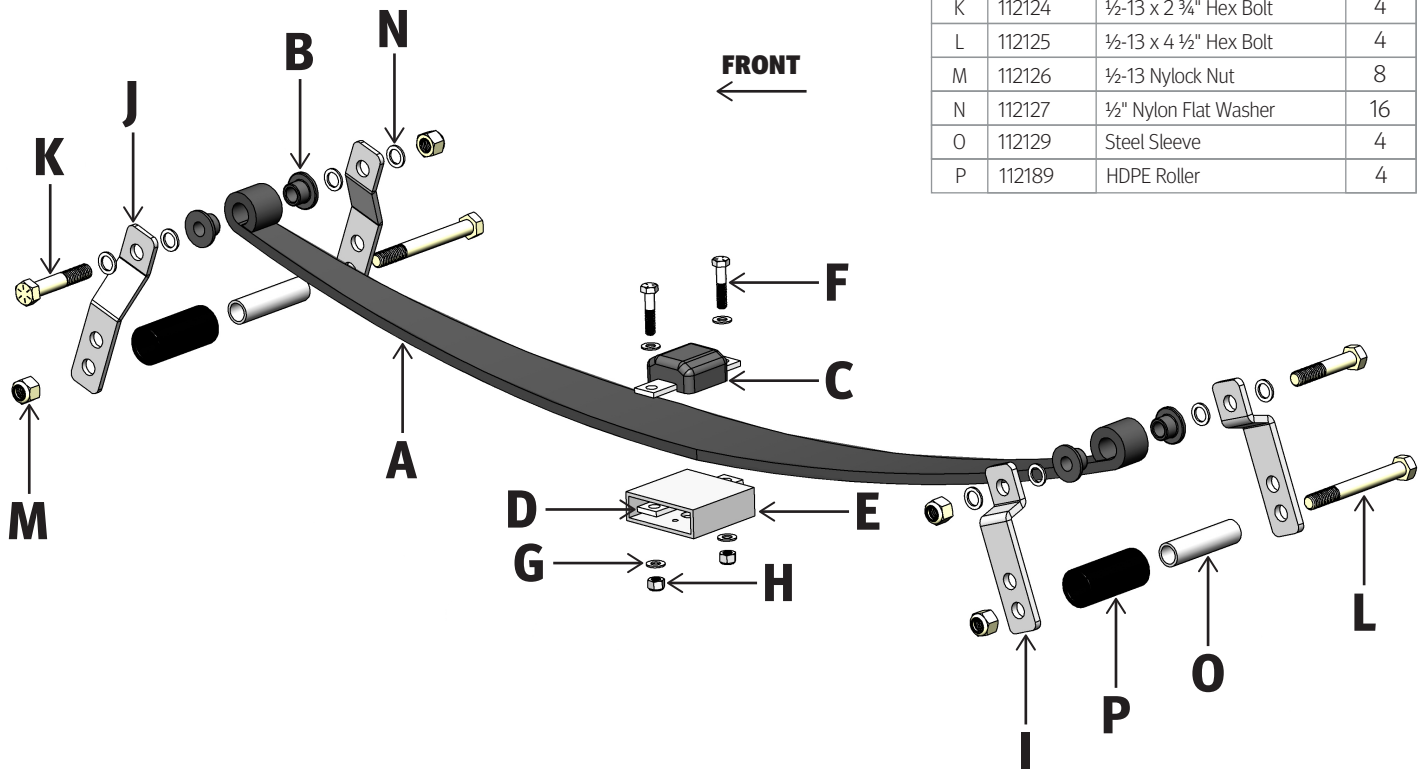

Part Number: SSA19

Product Line: SUPERSPRINGS

Page 1

Questions or Concerns?

Scan here:



or visit:
superspringsinternational.com

SAFETY NOTICE: We recommend installation be done by a professional or persons with sound mechanical knowledge.

WARNING: These instructions are a general guide for installation. SuperSprings International (SSI) assumes no liability for the actual installation process. Consumers and installers should apply common automotive safety practices when raising and working on any vehicle. **Do not put yourself in a position where, if the vehicle were to move unexpectedly, you may be injured.** SSI's products are designed to improve vehicle ride quality. Do not load any vehicle beyond the manufacturer's specifications.

Never exceed the manufacturer's Gross Vehicle Rating (GVWR) located on your vehicles identification tag.

BEFORE INSTALLATION: Ensure the vehicle is on a hard level surface, the parking brake is ON, with the ignition OFF, and place chocks in front of and behind the tires to prevent the vehicle from moving.

DURING AND/OR AFTER INSTALLATION: Ensure emergency brake cables are not touching the SSI products. Secure any cables out of the way with zip ties or by re-routing. Ensure all A/C lines, brake cables, and frame are clear of contact or interference.

REV. 2.01 | OCT 2023

PART NUMBER
SSA19



INSTALLATION

1. Positioning the vehicle – Vehicle must be on level solid surface. Ensure emergency brake is ON and Ignition is OFF. Chock both front and rear of the front tires to prevent the vehicle from moving.
2. Remove rubber bump-stop, With the vehicle still on the ground (one side at a time), loosen axle u-bolts to allow removal of the factory bump-stop. Retighten U-bolts as per Toyota’s specifications.
3. Place Mounting Block [ITEM E] between the factory U-bolts with the open ends perpendicular to the leaf springs. Ensure circular hole is face down over bolt through the factory spring pack. Tap mounting block into position.

Position the SuperSprings so there is sufficient clearance from any frame contact both horizontally and vertically.

4. Spring Orientation – The SSA19 has a dedicated front/rear. The end with the angle shackle goes to the front and the square shackle to the rear. Also, the threaded ends of the spring eye bolts and shackle bolts should be pointing outboard, away from the frame.
5. Remove Shackle Roller Assemblies – Using $\frac{3}{4}$ " tools, wrenches / sockets / ratchet, remove and set aside the bolts [ITEM L] and nuts [ITEM M] rollers [ITEM P] and sleeves [ITEM O] from the front and rear of the shackles. Rotate the shackles toward the center and parallel to the spring.
6. SuperSpring Install - Place the SuperSpring on top of the Mounting Block above the OE leaf pack.
7. Shackle Attachment - Note: The top/spring eye shackle bolts are factory pre-torqued; no adjustment/further tightening is needed. If any are loosened by the installer then retorque to 30 ft. lbs.
8. Shackle Attachment Front - Rotate the front shackles legs down on both sides of the leaf spring. Using ITL-1 or other high capacity clamp(s), compress the SuperSprings and factory leaf pack together. Place the Sleeve [ITEM O] and the Roller [ITEM P] between the Shackles and align with desired preload holes. Secure with $\frac{1}{2}$ -13 x 4 $\frac{1}{2}$ " Hex Bolt [ITEM L] and $\frac{1}{2}$ -13 Lock Nut [ITEM M]. Torque to 35 ft. lbs.
9. Shackle Attachment Rear – Rotate the front shackles legs down on both sides of the leaf spring. Using ITL-1 or other high capacity clamp(s), compress the SuperSprings and factory leaf pack together. Place the Sleeve [ITEM O] and the Roller [ITEM P] between the Shackles and align with desired preload holes. Secure with $\frac{1}{2}$ -13 x 4 $\frac{1}{2}$ " Hex Bolt [ITEM L] and $\frac{1}{2}$ -13 Lock Nut [ITEM M]. Torque to 35 ft. lbs.

Part Number: SSA19

Product Line: SUPERSPRINGS

Page 2

Questions or Concerns?

Scan here:



or visit:
superspringsinternational.com

SAFETY NOTICE: We recommend installation be done by a professional or persons with sound mechanical knowledge.

WARNING: These instructions are a general guide for installation. SuperSprings International (SSI) assumes no liability for the actual installation process. Consumers and installers should apply common automotive safety practices when raising and working on any vehicle. **Do not put yourself in a position where, if the vehicle were to move unexpectedly, you may be injured.** SSI's products are designed to improve vehicle ride quality. Do not load any vehicle beyond the manufacturer's specifications.

Never exceed the manufacturer's Gross Vehicle Rating (GVWR) located on your vehicles identification tag.

BEFORE INSTALLATION: Ensure the vehicle is on a hard level surface, the parking brake is ON, with the ignition OFF, and place chocks in front of and behind the tires to prevent the vehicle from moving.

DURING AND/OR AFTER INSTALLATION: Ensure emergency brake cables are not touching the SSI products. Secure any cables out of the way with zip ties or by re-routing. Ensure all A/C lines, brake cables, and frame are clear of contact or interference.

REV. 2.01 | OCT 2023

PART NUMBER

SSA19



INSTALLATION

10. Install hold down clamp - Slide the Bump Stop [ITEM C] onto one of the Clamp Plates [ITEM D] and place on top of the SuperSpring above the Mounting Block. Slide another Clamp Plate through the Mounting block and fasten together with two 5/16 Bolts [ITEM F], Washers [ITEM G] and Nut [ITEM H] and tighten securely.

11. Check final alignments Note: Springs do not have to be centered on mounting block over axle. Position springs to provide rear rollers with 3/4" forward clearance from any obstacles. Recheck that no A/C lines or brake cables will be interfered with by the vertical travel of the SuperSprings.

12. Repeat the same process on the other side. In some cases, the muffler hanger on the right side may interfere with the installation. In this case, drop the hanger attachment bracket to the lower screw position where it attaches to the frame.

13. Lower the vehicle – Remove the jack stands, lower to the ground. Remove wheel chocks from front wheels.

14. Final Check – Check the position of the SuperSprings ensuring for correct hardware application and orientation. Observe all hardware ensuring for static and dynamic interference clearances. Recheck all hardware to ensure it is securely tightened.

NOTE: After 200-500 miles of driving, recheck all hardware again for tightness.

15. Register the warranty for your SuperSprings International part. A warranty card can be found in the box your part came in.

Part Number: SSA19

Product Line: SUPERSPRINGS

Page 3

Questions or Concerns?

Scan here:



or visit:
superspringsinternational.com

SAFETY NOTICE: We recommend installation be done by a professional or persons with sound mechanical knowledge.

WARNING: These instructions are a general guide for installation. SuperSprings International (SSI) assumes no liability for the actual installation process. Consumers and installers should apply common automotive safety practices when raising and working on any vehicle. **Do not put yourself in a position where, if the vehicle were to move unexpectedly, you may be injured.** SSI's products are designed to improve vehicle ride quality. Do not load any vehicle beyond the manufacturer's specifications.

Never exceed the manufacturer's Gross Vehicle Rating (GVWR) located on your vehicles identification tag.

BEFORE INSTALLATION: Ensure the vehicle is on a hard level surface, the parking brake is ON, with the ignition OFF, and place chocks in front of and behind the tires to prevent the vehicle from moving.

DURING AND/OR AFTER INSTALLATION: Ensure emergency brake cables are not touching the SSI products. Secure any cables out of the way with zip ties or by re-routing. Ensure all A/C lines, brake cables, and frame are clear of contact or interference.

REV. 2.01 | OCT 2023