

PART NUMBER  
**TSS-107-40**



**PRODUCT INFORMATION**



**PRODUCT LINE**  
Trailer SumoSprings

**COLOR**  
Blue

**VARIATION**  
Spring-Over

**BOX INFORMATION**

**SHIPPING DIMENSIONS**



**BOX DESCRIPTION**  
Small SumoSprings Box

**TAPE MACHINE POSITION**  
#18 // 16" (40.64cm)

**BOX NUMBER**  
512502

**BILL OF MATERIALS**

Item	Part #	Description	QTY
A	511453	SumoSprings Blue -40	2
B	512116	3 x 1/2" Spacer	4
C	512151	Top Mounting Bracket	2
D	512152	Bottom Mounting Bracket	2
E	512362	M8 x 25mm Carriage Bolt	2
F	512363	M8 x 35mm Carriage Bolt	2
G	512364	M8 x 45mm Carriage Bolt	2
H	512323	3/8" Nyloc Nut	2
I	512244	5/16" Flat Washer	2
J	512211	3/8 x 3 1/2" Carriage Bolt	2
K	512123	Gas Line Bracket	3
L	512334	7/8" Loop Clamp	3
M	512335	10-24 x 1 1/4" Machine Screw	3
N	512336	10-24 Nyloc Nut	3
O	512337	#10 x 3/4" OD Fender Washer	6
P	512239	Blue Thread Locker	1
Q	512502	Small SumoSprings Box	1
R	122363	S-Badge Sticker	1
S	122366	SumoSprings Logo Sticker	1
T	122369	Warranty Card	1
U	INS_TSS-107-40/47	Install Guide	1

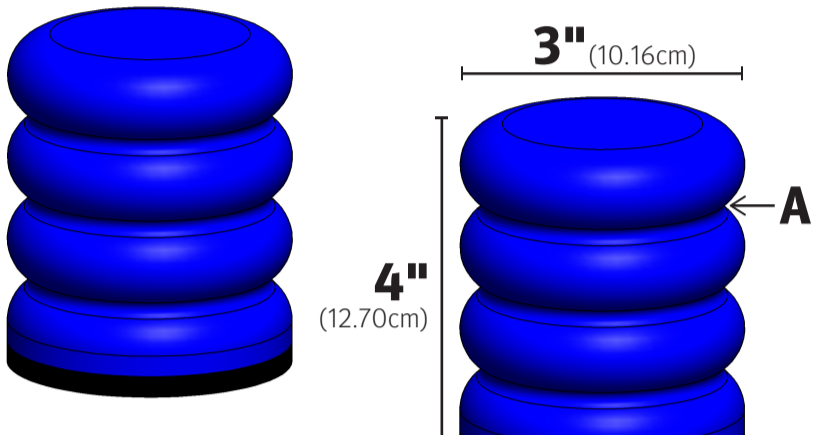
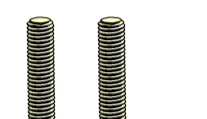
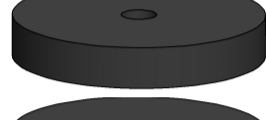
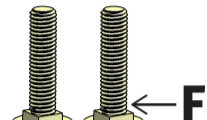
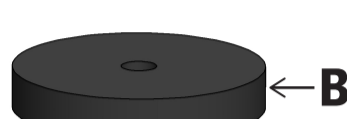
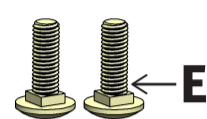
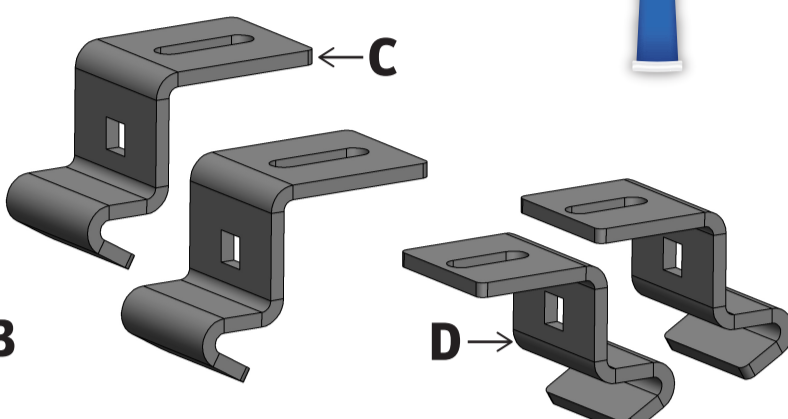

**TOOLS REQUIRED**

- > Protective gloves
- > Safety glasses
- > Heat sealer
- > 6" (15.24cm) Plastic tubing
- > Metal ruler
- > M-8 x 1.25 drill bit
- > Handheld drill
- > Air hose/compressed air
- > Protectant cleaner
- > Microfiber towel
- > Filler paper machine
- > Filler paper

**BEFORE YOU BEGIN**

**PLEASE NOTE**  
All of the following steps that are highlighted in yellow require you to wear protective gloves and safety glasses to complete.

**PACKING INSTRUCTIONS**

1. Print or retrieve one set of installation instructions per kit. Always use the current, approved, document revision.
2. Fold instructions in half, placing the warranty card and stickers within the folded document. Set them aside.
3. Locate and review components needed to build kit as listed in the Bill of Materials section.
4. Start by building the kit box according to the Box Guide.
5. Retrieve the 6" (15.24cm) wide plastic tubing to create a small bag for kit accessories.

6. Using the heat sealer, set the heat settings at #4. Measure the roll to 13" (33.02cm), press sealer arm down across the plastic roll for 2 seconds to create a sealed closure (HEAT SEAL 1). Press the cut button to release the roll, creating a bag.

7. Inside the bag place:

Section 1: ~ 5" (12.70cm) C x2 & D x2 (HEAT SEAL 2)	Section 2: ~ 1 1/2" (3.81cm) E x2, F x2, & G x2 (HEAT SEAL 3)	Section 3: ~ 1 1/2" (3.81cm) H x2, I x2, & J x2 (HEAT SEAL 4)	Section 4: ~ 4" (10.16cm) K x3, L x3, M x3, N x3, & O x6 (HEAT SEAL 5)	Section 5: ~ 1" (2.54cm) P x1
--	--	--	---	-------------------------------------

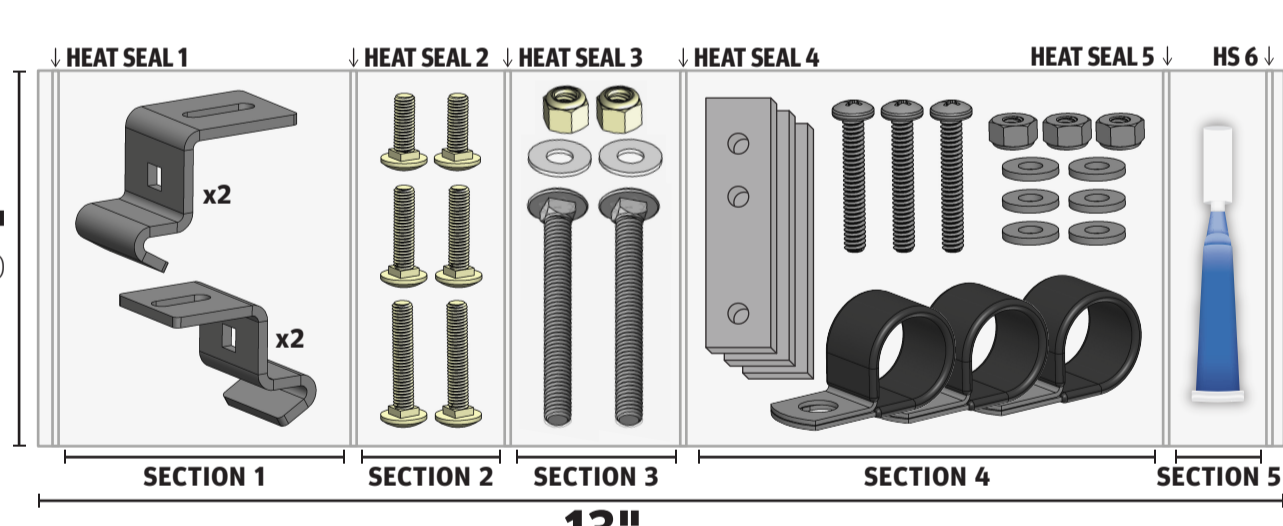

8. Insert the opening of the bag into the heat sealer and repeat step 6 to seal the bag closed (HEAT SEAL 6). Set bag aside.

9. Visually inspect the height of the two SumoSprings, and ensure they match each other. If not, select another component until both match in height. If needed, use the metal ruler for assistance with accuracy.

10. SumoSprings will need to have the thread cleaned. For this, use the hand drill and a M-8 x 1.25 drill bit.

11. On the hand drill, turn drill speed to the #1.

12. Place the M-8 x 1.25 drill bit into the thread of the SumoSprings approximately 1/2" (1.27cm). Thread is located at the top center of the SumoSprings component. Turn drill on until the glue and plastic are removed from the thread. Approximate drill time is 2 to 5 seconds. Once complete, make sure the drill is turned off in a secure location.

13. Using the air hose, or compressed air, clean off the SumoSprings for any residue left over from drilling. Place the air hose, or compressed air, back in its secure location.

14. Using a microfiber towel and a small amount of protectant cleaner, wipe clean the SumoSprings of any dust or debris. Set aside the SumoSprings.

15. Place the SumoSprings in the box (refer to diagram below). Using the filler paper machine, release enough paper to fill the space in the box. The SumoSprings should fit snug with little to no movement.

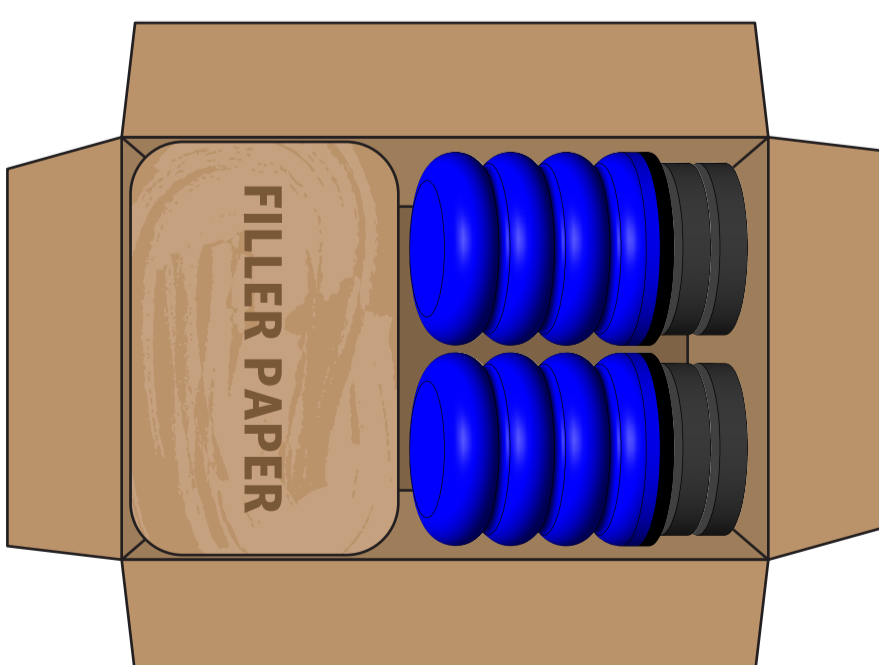

16. Place the 13" (33.02cm) bag with accessories in the box, on top of the SumoSprings.

17. Retrieve the installation instructions packet, which should contain the warranty card and SSI sticker, and place it on top of the components in the box.

18. Close the top of the box by completing the steps referenced in the Box Guide.

19. Using the scanner (refer to scanner instructions) print out a label.

20. Position label vertically, on the left side of the end of the box with the SuperSprings International logo side to the left (refer to Completed Kit Diagram).

21. Place the finished kit in the applicable bin.

**COMPLETED KIT**



**COMPLETED KIT WEIGHT**  
13lbs (8.89 kg.)