

PART NUMBER  
**SSF-327-47**



**PRODUCT INFORMATION**

**BOX INFORMATION**



**SHIPPING DIMENSIONS**



**PRODUCT LINE**  
SumoSprings  
**VARIATION**  
Solo

**COLOR**  
Black

**BOX DESCRIPTION**  
Small SumoSprings Box  
**BOX NUMBER**  
512502

**TAPE MACHINE POSITION**  
#18 // 16" (40.64cm)

**BILL OF MATERIALS**

Item	Part #	Description	QTY
A	511426	SumoSprings Black -47	2
B	512009	2 1/2" Spacer	2
C	512215	M8 Flat Washer	2
D	512214	M8 Hex Nut	2
E	512239	Blue Thread Locker	1
F	512502	Small SumoSprings Box	1
G	122363	S-Badge Sticker	1
H	122366	SumoSprings Logo Sticker	1
I	122369	Warranty Card	1
J	INS_SSF-327-47	Install Guide	1

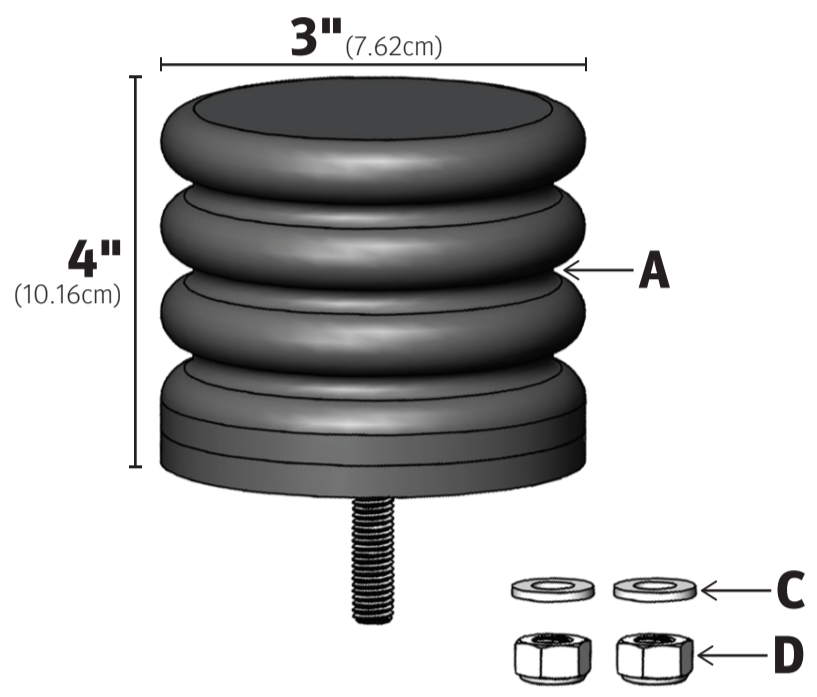
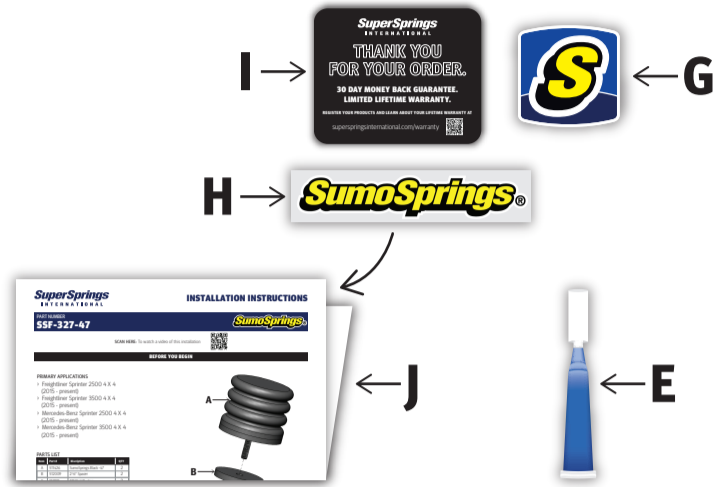

**TOOLS REQUIRED**

**BEFORE YOU BEGIN**

- > Protective gloves
- > Safety glasses
- > Heat sealer
- > 4" (10.16cm) Plastic tubing
- > Metal ruler
- > Protectant cleaner
- > Microfiber towel
- > Filler paper machine
- > Filler paper

**PLEASE NOTE**

All of the following steps that are highlighted in yellow require you to wear protective gloves and safety glasses to complete.

**PACKING INSTRUCTIONS**

1. Print or retrieve one set of installation instructions per kit. Always use the current, approved, document revision.
2. Fold instructions in half, placing the warranty card and stickers within the folded document. Set them aside.
3. Locate and review components needed to build kit as listed in the Bill of Materials section.
4. Start by building the kit box according to the Box Guide.
5. Retrieve the 4" (10.16cm) wide plastic tubing to create a small bag for kit accessories.

6. Using the heat sealer, set the heat settings at #4. Measure the roll to 6" (15.24cm), press sealer arm down across the plastic roll for 2 seconds to create a sealed closure (HEAT SEAL 1). Press the cut button to release the roll, creating a bag.

7. Inside the bag place:

Section 1:  
~ 3" (7.62cm)  
B x2  
(HEAT SEAL 2)

Section 2:  
~ 1" (2.54cm)  
C x2, D x2  
(HEAT SEAL 3)

Section 3:  
~ 1 1/2" (3.81cm)  
E x1

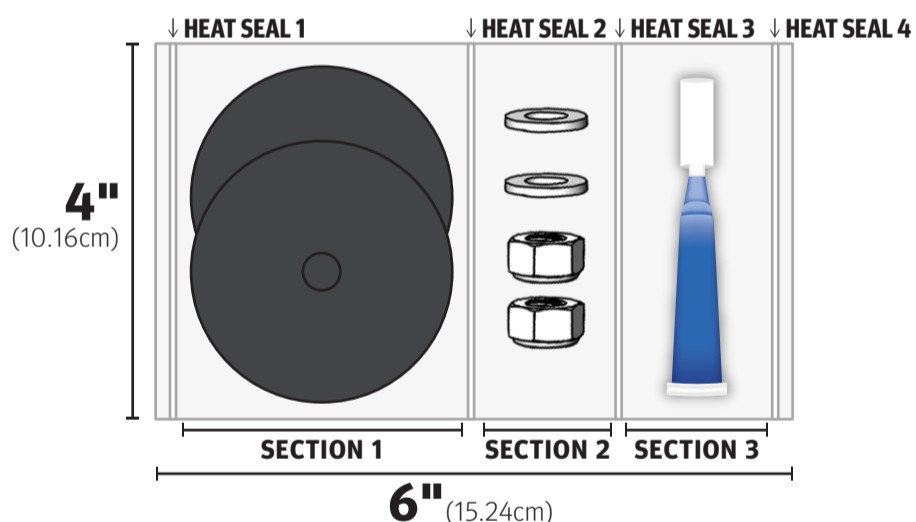

8. Insert the opening of the bag into the heat sealer and repeat step 6 to seal the bag closed (HEAT SEAL 4). Set bag aside.

9. Visually inspect the height of the two SumoSprings, and ensure they match each other. If not, select another component until both match in height. If needed, use the metal ruler for assistance with accuracy.

10. Use the microfiber towel and a small amount of protectant cleaner, finish cleaning the SumoSprings of debris and dust.

11. Place the SumoSprings in the box (refer to diagram below). Using the filler paper machine, release enough paper to fill the spaces in the box. The SumoSprings should fit snug with little to no movement.

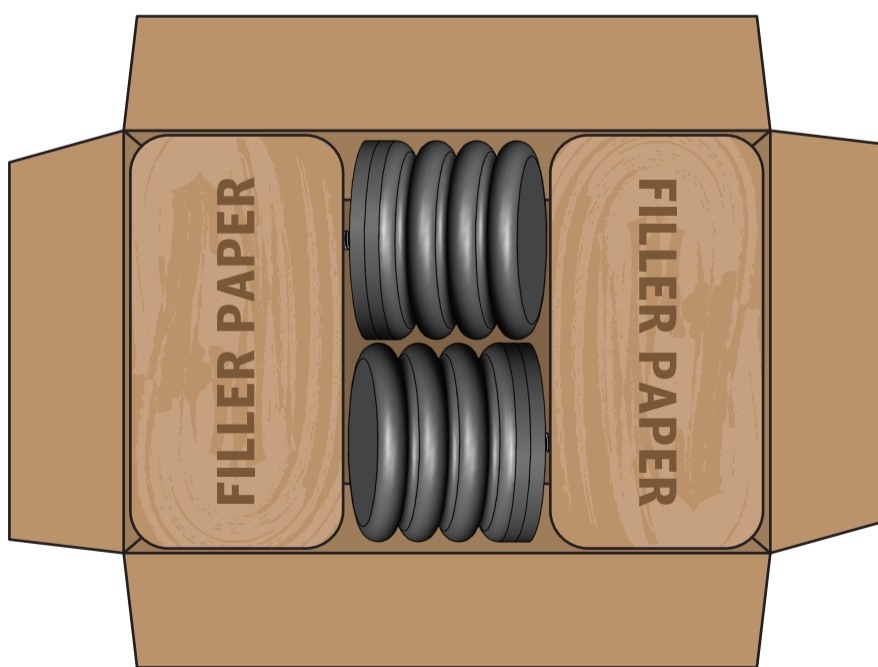

12. Place the 6" (15.24cm) bag with the accessories in the box, on top of the SumoSprings.

13. Retrieve the installation instructions packet, which should contain the warranty card and SSI sticker, and place it on top of the components in the box.

14. Close the top of the box by completing the steps referenced in the Box Guide.

15. Using the scanner (refer to scanner instructions) print out a label.

16. Position label vertically, on the left side of the end of the box with the SuperSprings International logo side to the left (refer to Completed Kit Diagram).

17. Place the finished kit in the applicable bin.

**COMPLETED KIT**



**COMPLETED KIT WEIGHT**  
4lbs (1.81 kg.)